

PRODUCT SPECIFICATION

2.4" IPS LCD Module with SPI Interface
DT024ETFT-IPS, DT024ETFT-IPS-SHB



Revision 1.1
25 May 2024

Displaytech, a SEACOMP company

Phone: 1.760.918.6722

sales@seacomp.com

www.seacomp.com

Contents of this document are subject to change without notice. No part of this document may be reproduced or transmitted in any form or by any means, electronic or physical, for any purpose, without the express written permission of Displaytech.

Revision History

REV	DESCRIPTION	DATE	APPR
1.0	Initial release	14 AUG 2023	PRW
1.1	Correct pin description, pins 10 & 11	25 MAY 2024	KRK

Table of Contents

1 Overview	1
1.1 Applications	1
1.2 Features	1
1.3 Acronyms	1
2 Pin Descriptions	2
2.1 MCU Serial Interface Mode	2
3 Specifications	3
3.1 Absolute Maximum Ratings	3
3.2 Electrical Characteristics	3
3.2.1 LED Backlight Circuit	4
4 AC Timing Characteristics	5
4.1 3-Line Serial Interface	5
4.2 4-Line Serial Interface	6
4.4 Reset Timing	7
5 Optical Characteristics	8
5.1 Figures	9
6 Environmental/Reliability Tests	11
6.1 Inspection Criteria	11
7 Precautions for Use of LCD Modules	12
7.1 Safety	12
7.2 Handling	12
7.3 Static electricity	12
7.4 Storage	12
7.5 Cleaning	12
7.6 Cautions for installation and assembly	12
8 Mechanical Drawings	13
8.1 DT024ETFT-IPS	13
8.2 DT024ETFT-IPS-SHB	14

1 Overview

The **DT024ETFT-IPS** and **DT024ETFT-IPS-SHB** are 2.4” color IPS LCD modules, each composed of a LCD panel, display drivers, FPC display cable with SPI interface, and adjustable LED backlight unit. The display’s active area has a resolution of 240 x 320 pixels. The DT024ETFT-IPS-SHB, with twice the number of backlight LEDs, is available as a “super high-bright” alternative to the DT024ETFT-IPS.

1.1 Applications

- Video Systems
- Mobile Systems
- Wearable devices

1.2 Features

- Size 2.4 Inches
- Resolution 240 (RGB) x 320 Pixels
- Type IPS, Normally Black, Transmissive
- Interface 3-Line SPI, 4-Line SPI
- Module Dimensions
 - DT024ETFT-IPS 42.52 mm (W) x 59.86 mm (L) x 2.40 mm (H)
 - DT024ETFT-IPS-SHB 42.52 mm (W) x 59.86 mm (L) x 2.50 mm (H)
- Active Area 36.72 mm (W) x 48.96 mm (L)
- Pixel Pitch 0.153 mm (W) x 0.153 mm (L)
- Viewing Direction All
- Backlight Type LED, White
- LCD Driver ILI9341

1.3 Acronyms

- FPC Flexible Printed Circuit
- LCD Liquid Crystal Display
- LED Light Emitting Diode
- RGB Red-Green-Blue
- SPI Serial-Peripheral Interface

2 Pin Descriptions

LCD INTERFACE ¹			
PIN	NAME	TYPE	DESCRIPTION
1	GND	PWR	Ground
2	VDDIO	PWR	Power supply, logic
3	VDD	PWR	Power supply, analog
4	$\overline{\text{CS}}$	I	Chip select (active low)
5	$\overline{\text{RESET}}$	I	Display reset, (active low)
6	SDIO	I/O	Serial input/output
7	GND	PWR	Ground
8	D/CX	I	Data/Command selection (0: Command, 1: Data)
9	SCL	I	Serial clock
10	IM1	I	See MCU Serial Interface Mode Selection table
11	IM0	I	See MCU Serial Interface Mode Selection table
12	TE	O	Tearing effect (active high). Leave open when not in use. ²
13	LED-A	PWR	LED backlight, anode
14	LED-K	PWR	LED backlight, cathode
15	LED-K	PWR	LED backlight, cathode

2.1 MCU Serial Interface Mode

SERIAL INTERFACE MODE SELECTION		
IM1	IM0	MODE
0	1	3-wire 9-bit data serial interface II
1	0	4-wire 8-bit data serial interface II

¹ Recommended mating connector: 5051101592 (or equivalent)

² See ILI9341 datasheet for details

3 Specifications

3.1 Absolute Maximum Ratings³

ELECTRICAL				
PARAMETER		MIN	MAX	UNITS
Supply Voltage, Analog	V_{DD}	-0.3	4.6	V
Supply Voltage, Logic	V_{DDIO}	-0.3	4.6	V
Logic Input Voltage	V_{IN}	-0.3	$V_{DDIO} + 0.3$	V
Logic Output Voltage	V_{OUT}	-0.3	$V_{DDIO} + 0.3$	V
Forward Current, Backlight	I_F	30	60	mA

ENVIRONMENTAL				
PARAMETER		MIN	MAX	UNITS
Operating Temperature	T_{OP}	-20	70	°C
Storage Temperature	T_{ST}	-30	80	°C

3.2 Electrical Characteristics⁴

POWER					
PARAMETER		MIN	TYP	MAX	UNITS
Supply Voltage, Analog	V_{DD}	2.5	2.8	3.3	V
Supply Voltage, Logic	V_{DDIO}	2.5	2.8	3.3	V
Supply Current	I_{DD}	–	10	15	mA

LOGIC					
PARAMETER		MIN	TYP	MAX	UNITS
Logic Input, High	V_{IH}	$0.7 \times V_{DDIO}$	–	V_{DDIO}	V
Logic Input, Low	V_{IL}	GND	–	$0.3 \times V_{DDIO}$	V
Logic Output, High	V_{OH}	$0.8 \times V_{DDIO}$	–	V_{DDIO}	V
Logic Output, Low	V_{OL}	GND	–	$0.2 \times V_{DDIO}$	V

³ Operation outside of the maximum ratings listed below may result in permanent damage to the LCD.

⁴ $T_A = 25^\circ\text{C}$

LED BACKLIGHT					
PARAMETER		MIN	TYP	MAX	UNITS
Forward Current	I_F	30	40	60	mA
Forward Voltage	V_F	DT024ETFT-IPS ⁵	–	9.9	V
		DT024ETFT-IPS-SHB ⁶	–	19.8	
LED Lifetime ⁷		–	30,000	–	Hrs

3.2.1 LED Backlight Circuit

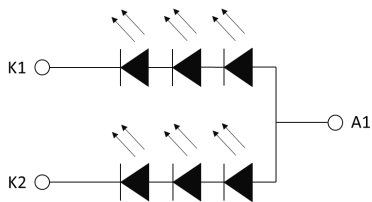

Figure 1: DT024ETFT-IPS Backlight
 2 x 3 = 6 LEDs, $I_F = 40$ mA

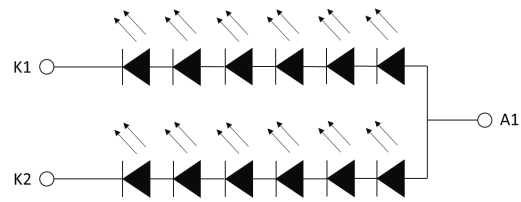

Figure 2: DT024ETFT-IPS-SHB Backlight
 2 x 6 = 12 LEDs, $I_F = 40$ mA

⁵ DT024ETFT-IPS backlight power consumption: 594mW (Max.)

⁶ DT024ETFT-IPS-SHB backlight power consumption: 1.19W (Max.)

⁷ LED lifetime is defined as the amount of time it takes for brightness to decrease to 50% of its original value at $T_A=25^\circ\text{C}$ and $I_F=40\text{mA}$. LED lifetime may decrease if operating current, I_F , is larger than 40mA.

4 AC Timing Characteristics

4.1 3-Line Serial Interface

Figure 3: 3-Line Serial Interface Timing

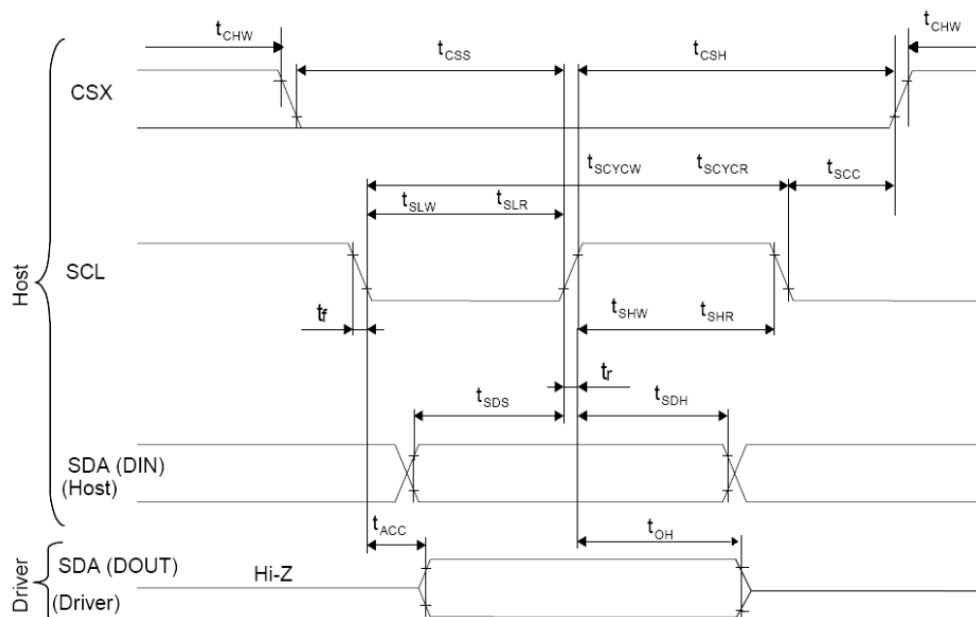

AC TIMING CHARACTERISTICS, 3-LINE SERIAL INTERFACE					
SIGNAL	PARAMETER		MIN	MAX	UNITS
SCL	Serial clock cycle (write)	t_{SCYCW}	100	–	nS
	SCL "H" pulse width (write)	t_{SHW}	40	–	nS
	SCL "L" pulse width (write)	t_{SLW}	40	–	nS
	Serial clock cycle (read)	t_{SCYCR}	150	–	nS
	SCL "H" pulse width (read)	t_{SHR}	60	–	nS
	SCL "L" pulse width (read)	t_{SLR}	60	–	nS
SDIO (Input)	Data setup time (write)	t_{SDS}	30	–	nS
	Data hold time (write)	t_{SDH}	30	–	nS
SDIO (Output) ⁸	Access time (read)	t_{ACC}	10	–	nS
	Output disable time (read)	t_{OH}	10	50	nS
\overline{CS}	SCL - CSX	t_{SCC}	20	–	nS
	CSX "H" pulse width	t_{CHW}	40	–	nS
	CSX SCL time	t_{CSS}	60	–	nS
		t_{CSH}	65	–	nS

⁸ Maximum $C_L = 30\text{pF}$; Minimum $C_L = 8\text{pF}$

4.2 4-Line Serial Interface

Figure 4: 4-Line Serial Interface Timing

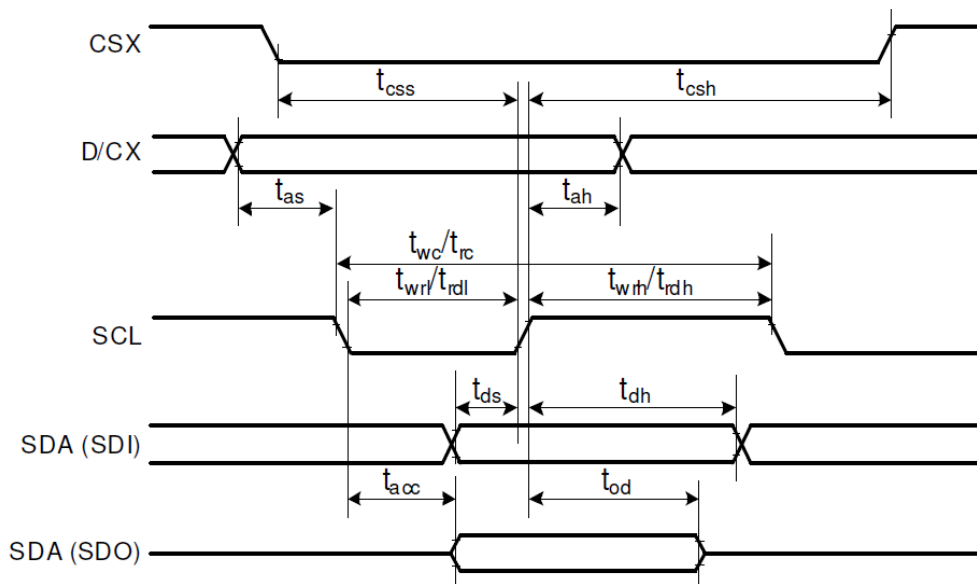

AC TIMING CHARACTERISTICS, 4-Line Serial Interface					
SIGNAL	PARAMETER		MIN	MAX	UNITS
\overline{CS}	Chip select time (write)	t_{css}	40	–	nS
SCL	Chip select hold time (read)	t_{csh}	40	–	nS
	Serial clock cycle (write)	t_{wc}	100	–	nS
	SCL "H" pulse width (write)	t_{wrh}	40	–	nS
	SCL "L" pulse width (write)	t_{wrl}	40	–	nS
	Serial clock cycle (read)	t_{rc}	150	–	nS
	SCL "H" pulse width (read)	t_{rdh}	60	–	nS
	SCL "L" pulse width (read)	t_{rdl}	60	–	nS
D/CX	D/CX setup time	t_{as}	10	–	
	D/CX hold time (write/read)	t_{ah}	10	–	
SDIO (Input)	Data setup time (write)	t_{ds}	30	–	nS
	Data hold time (write)	t_{dh}	30	–	nS
SDIO (Output) ⁹	Access time (read)	t_{acc}	10	–	nS
	Output disable time (read)	t_{od}	10	50	nS

⁹ Maximum $C_L = 30\text{pF}$; Minimum $C_L = 8\text{pF}$

4.4 Reset Timing

Figure 5: Reset Timing

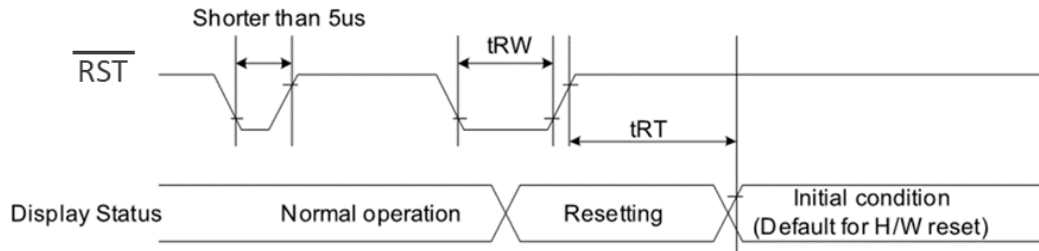

RESET TIMING ¹⁰				
PARAMETER		MIN	MAX	UNIT
Reset pulse duration	t_{RW}	10	–	μS
Reset cancel	t_{RT}	–	5	mS
		–	120	mS

¹⁰ Refer to ILI9341 driver datasheet for details

5 Optical Characteristics

OPTICAL CHARACTERISTICS ¹¹						
PARAMETER		MIN.	TYP.	MAX.	UNIT	
Contrast Ratio ^{12,13}	CR	600	800	–	–	
Response Time ¹⁴	T _{ON} / T _{OFF}		30	40	mS	
View Angles ^{15,16}	ΘT	–	80	–	Degrees	
	ΘB	–	80	–		
	ΘL	–	80	–		
	ΘR	–	80	–		
Chromaticity ¹⁷	X _{WHT}	0.3050	0.3250	0.3450	–	
	Y _{WHT}	0.3404	0.3604	0.3804		
	X _{RED}	0.6351	0.6551	0.6751		
	Y _{RED}	0.3034	0.3234	0.3432		
	X _{GRN}	0.3282	0.3482	0.3682		
	Y _{GRN}	0.5828	0.6028	0.6228		
	X _{BLU}	0.0864	0.1064	0.1264		
	Y _{BLU}	0.0364	0.0564	0.0764		
Luminance ¹³	DT024ETFT-IPS	L	–	350	–	Cd/m ²
	DT024ETFT-IPS-SHB		–	1000 (SHB)	–	
Uniformity ¹³	U	80	–	–	%	

¹¹ See Section 5.1, Figure 3

¹² Viewing Angle (Θ) = 0°

¹³ See Section 5.1, Figure 7

¹⁴ See Section 5.1, Figure 4

¹⁵ Contrast Ratio (CR) ≥ 10

¹⁶ See Section 5.1, Figure 5

¹⁷ See Section 5.1, Figure 6

5.1 Figures

Figure 3: Optical Measurement System

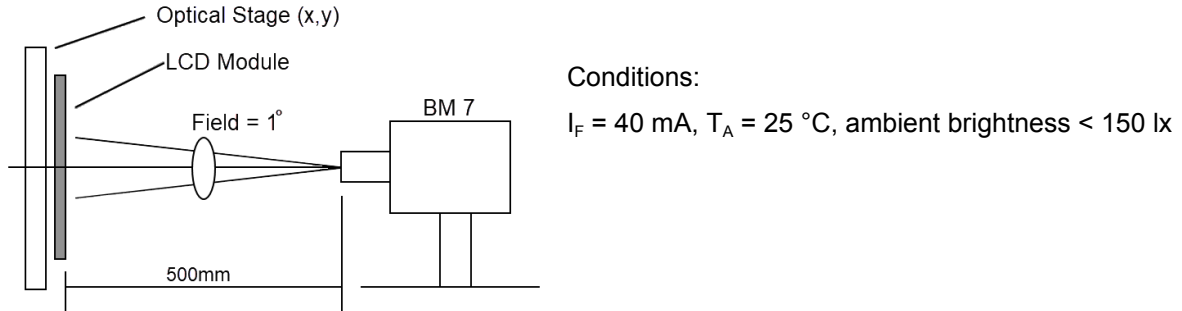

Figure 4: Response Times

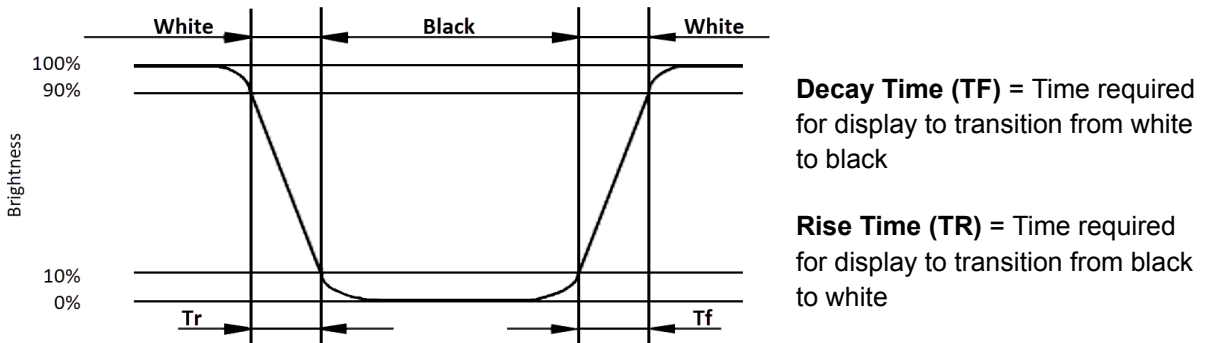

Figure 5: Viewing Angles

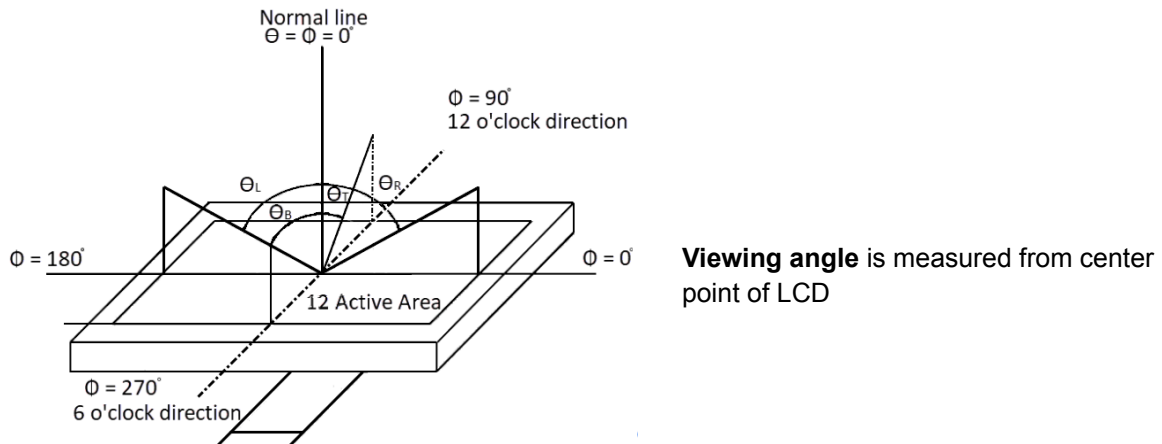
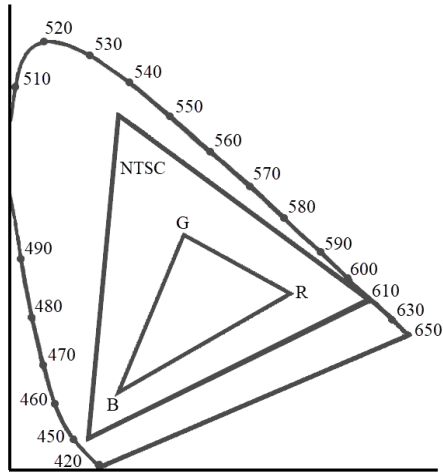

Figure 6: Chromaticity (CIE 1931)



Chromaticity = Area of Δ_{RGB} / Area of Δ_{NTSC}

* Color coordinates measured at center point of LCD

Figure 7: Luminance Uniformity

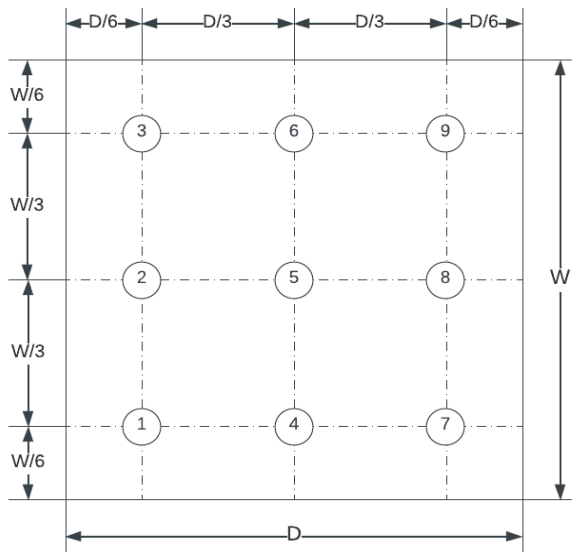

Luminance is defined as the brightness of all white pixels at the center of the display area at optimum contrast.

Uniformity is determined by measuring Luminance at 9 points and calculating $Luminance_{MIN} / Luminance_{MAX}$

Contrast Ratio = $\frac{Surface\ Luminance_{WhitePixels}}{Surface\ Luminance_{BlackPixels}}$

6 Environmental/Reliability Tests

Judgment is based on inspection performed after testing, per criteria described in the Inspection Criteria table.¹⁸

ITEM UNDER TEST	TEST CONDITION
High temp operation	$T_A = 70\text{ }^\circ\text{C}$, 120 Hrs.
Low temp operation	$T_A = -20\text{ }^\circ\text{C}$, 120 Hrs.
High temp storage	$T_S = 80\text{ }^\circ\text{C}$, 120 Hrs.
Low temp storage	$T_S = -30\text{ }^\circ\text{C}$, 120 Hrs.
High temp & high humidity storage	$T_S = 60\text{ }^\circ\text{C}$, 120 Hrs., 90% RH
Thermal shock (non-operation)	$-30\text{ }^\circ\text{C}$, 30 min \rightarrow $80\text{ }^\circ\text{C}$, 30 min Change time: 5 min, 10 cycles
ESD (operation)	C = 150 pF, R = 330 Ω , 5 points/panel Air: $\pm 8\text{ KV}$, 5 times Contact: $\pm 4\text{ KV}$, 5 times
Vibration (non-operation)	Frequency range 10 - 55 Hz. Stroke: 1.5 mm Sweep 10 Hz \rightarrow 55 Hz \rightarrow 10 Hz 2 hours for each direction of X, Y, Z
Package drop test	Height 80 cm 1 corner, 3 edges, 6 surfaces

6.1 Inspection Criteria

All testing shall be judged based upon the criteria in this table.

INSPECTION ITEM	CRITERIA
Appearance	No cracks on FPC No cracks on LCD panel
Alignment of LCD panel	No bubbles in LCD panel No alignment defects in LCD active area
Electrical current	Within device specifications
Function / Display	No broken circuits, no short circuits No black lines No other display defects

¹⁸ Functional test shall be conducted after 4 hours of storage at normal temperature and humidity, after LCD is removed from test chamber.

7 Precautions for Use of LCD Modules

7.1 Safety

Liquid crystal in LCD is poisonous. Do not put in mouth. If liquid crystal comes in contact with skin or clothes, wash it off immediately using soap and water.

7.2 Handling

- A. The LCD panel is made of plate glass. Do not subject the panel to mechanical shock or excessive force on its surface.
- B. In order to ensure reliability, do not hold product by flexible printed circuit (FPC) cable.
- C. Provide space so that panel does not come into contact with other components.
- D. To protect the product from external force, apply a covering lens (acrylic board or similar) and keep an appropriate gap between them.
- E. Transparent electrodes may be disconnected if the panel is used in an environment where dew condensation is present.
- F. Properties of semiconductor devices may be affected when exposed to light, possibly resulting in IC malfunctions. To prevent such malfunctions, design and mounting layout should be done in such a way that IC is not exposed to light in actual use.

7.3 Static electricity

- A. Ground soldering iron tips, tools and testers when they are in operation.
- B. Ground your body when handling the products.
- C. Power on the LCD module before applying the voltage to the input terminals.
- D. Do not apply voltage which exceeds the absolute maximum rating.
- E. Store the products in an anti-electrostatic bag or container.

7.4 Storage

- A. Store product in a dark place at $+25^{\circ}\text{C} \pm 10^{\circ}\text{C}$ with low humidity (40% RH ~ 60% RH). Do not expose the display to sunlight or fluorescent light.
- B. Storage in a clean environment, free from dust, active gas, and solvent.

7.5 Cleaning

- A. To clean the product, wipe with a soft cloth moistened with ethanol. Do not allow ethanol to get between upper film and bottom glass, as this may cause peeling issues and/or defective operation. Do not use any organic solvent or detergent other than ethanol.

7.6 Cautions for installation and assembly

- A. Bezel edge must be positioned between Active area and Viewing area.
- B. For a stable display assembly, Displaytech recommends designing a support for the backside of the display.
- C. Do not display any fixed pattern for long periods of time. If a fixed pattern must be displayed, use a screen saver in order to avoid image persistence.

8 Mechanical Drawings

8.1 DT024ETFT-IPS

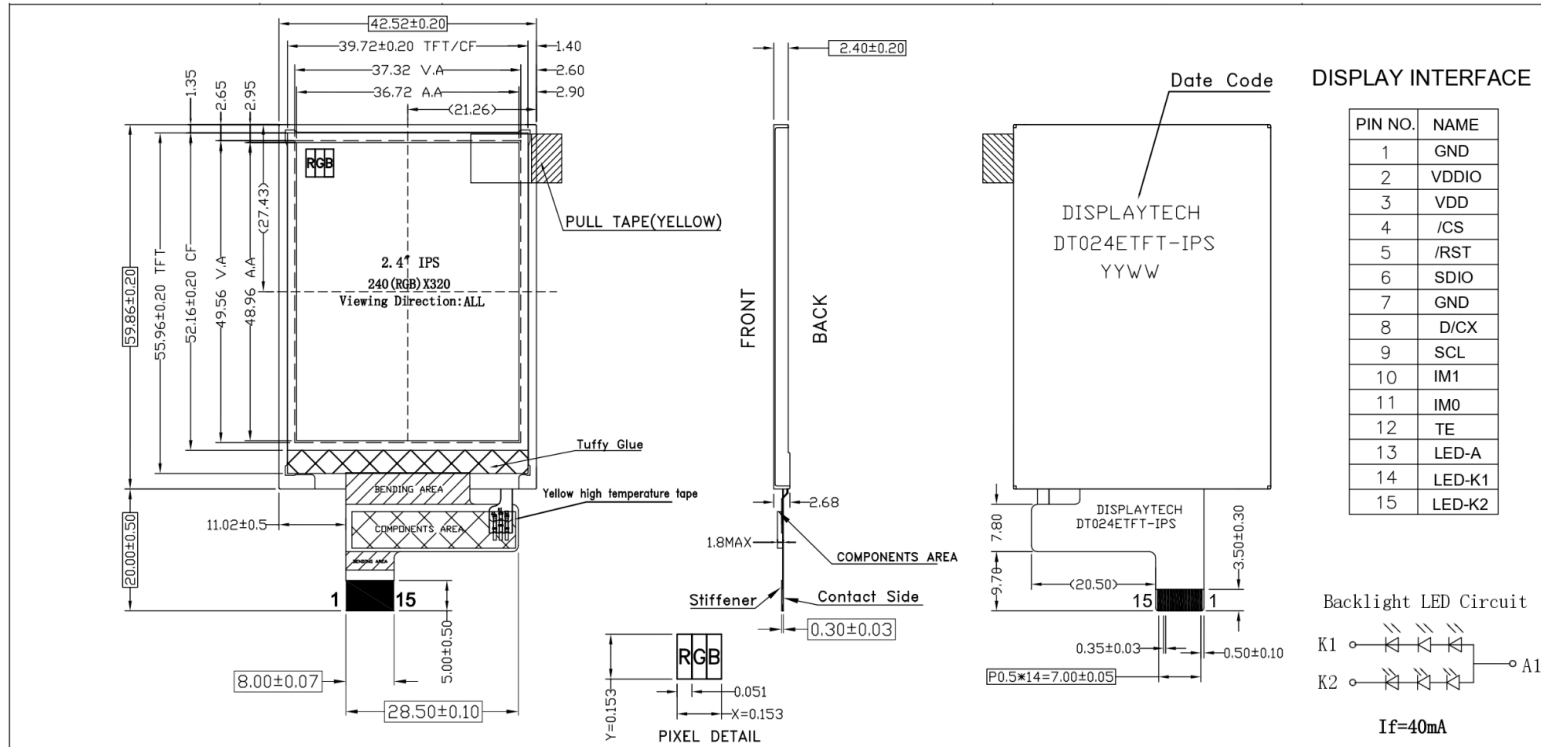

Notes

1. Display Type: 2.4" IPS
2. Display Mode: Transmissive/Normally Black
3. Viewing Direction: ALL
4. Backlight : 6PCS WHITE LED , If=40mA
5. Display Driver IC. : ILI9341V
6. VDD=VDDIO =2.8V
7. Luminance : 350 cd/m² (Typ.)
8. Operating Temperature: -20°C to 70°C ; Storage Temperature: -30°C to 80°C
9. General Tolerance : ±0.20mm
10. Environmental Protections Requirements(s): RoHS
11. (.) =Reference Dimension; □ =Critical/Inspection Dimension

Count drawing & Spec.revision record during discussion with customer

Rec.	Revision	Content Description	Date
#00	FIRST ISSUE		2020.09.10
#01	Modify Dimension		2020.11.06
#02	Modify Dimension		2020.11.25
#03	Modify Dimension		2021.01.18
	Modify IC PIN from ILI9341 to ILI9341V		2021.01.21

SCALE	SHEET
NTS	1/1

UNIT	SIZE	DESIGNER	CHECK	APPROVER	FILE NAME
mm	A4	Felix Feng	Ken Li	Jones Hsieh	Count Dwg.

Mod.Name **DT024ETFT-IPS**

8.2 DT024ETFT-IPS-SHB

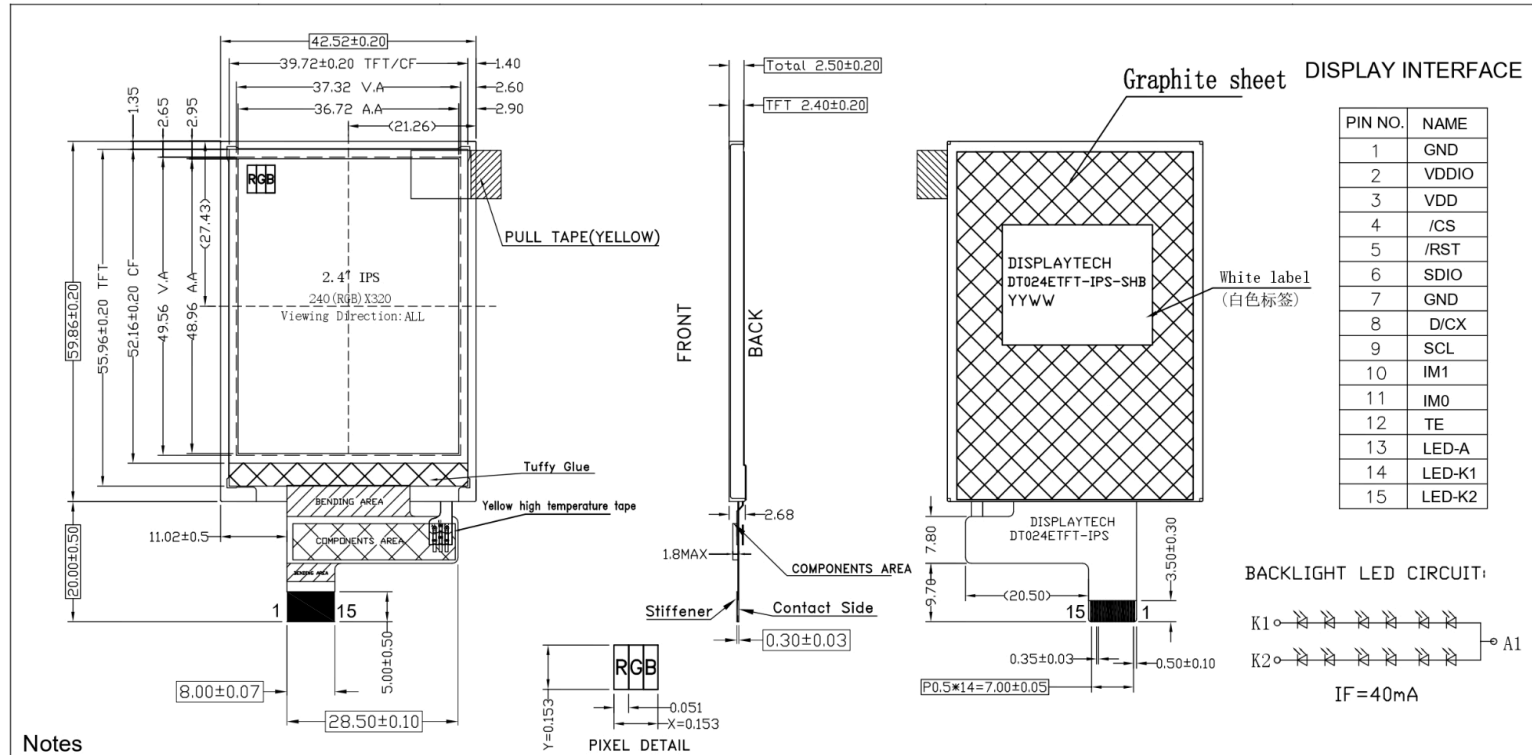

Notes

1. Display Type: 2.4" IPS
2. Display mode: TRANSMISSIVE/Normally Black
3. Viewing Direction: ALL
4. Back light : 12PCS WHITE LED(2*6), IF=40mA
5. LCM DRIVER IC. : ILI9341V
6. VDD=IOVCC =2.8V
7. Luminance : 1000(Typ.)
8. Operating Temperature: -20°C to 70°C; Storage Temperature: -30°C to 80°C
9. General tolerance : ±0.2mm
10. Environmental Protections Requirements(s): RoHS
11. ()=Reference Dimension; □ =Critical/Inspection Dimension

Count drawing & Spec.revision record during discussion with customer

Rev.	Revision content description	Date
#00	FIRST ISSUE	2020.09.10
#01	Modify Dimension	2020.11.06
#02	Modify Dimension	2020.11.25
#03	Modify backlight led circuit. Modify IC PIN from ILI9341 to ILI9341V	2021.01.21 2021.01.22

a seacompany company

Mod.Name

DT024ETFT-IPS-SHB

UNIT
mm

SIZE
A4

DESIGNER
Felix Feng

CHECK
Ken Li

APPROVER
Jones Hsieh



SCALE SHEET

NTS 1/1

FILE NAME
Count Dwg.